



LS160 LS170

Workshop
Manual

Workshop
Manual

Print No. 604.13.607
English - Printed in Italy

SECTION 00 – GENERAL INFORMATION

CONTENTS

Section	Description	Page
	Introduction	00-2
	About Improvements	00-2
	Company Policy	00-3
	Parts and Accessories	00-3
	Model Codes	00-3
	Precautionary Statements	00-4
	Safety Precaution Information	00-5
	General Safety Information	00-7
	Machine Model and Serial Number Location	00-9
	Engine Model and Serial Number Location	00-9
	Hardware Torque Specifications	00-10
	Installation of Adjustable Fittings in Straight Thread O Ring Bosses	00-12
	Standard Torque Data for Hydraulic Tubes and Fittings	00-12
	Pipe Thread Fitting Torque	00-13
	Lubricants and Coolants	00-13
	Sealants	00-13
	Properly Support a Raised Machine	00-14
	Properly Support Boom on Boom Lock Pins	00-14
	Raising Boom Without Hydraulic Oil Flow	00-14
	Raising Boom Without Battery Voltage (12V)	00-16
	Reattaching Cylinders After Repair with Boom Resting on Boom Lock Pins	00-17
	Major Unit Overhaul	00-18
	Cab and Boom Tilt Procedure	00-19
	Craning the Skid Steer	00-25
	Special Tools	00-28
	Specifications	00-29
	Dimensions	00-35

INTRODUCTION

This service manual provides the technical information needed to properly service and maintain the Models LS160 and LS170 skid steers. Use it in conjunction with the operator's manual which is supplied with the skid steer. Keep both manuals available for ready reference.

The L160 and L170 have many similarities with the major differences being engine horsepower and lifting capacity.

Whenever working on New Holland equipment, left and right sides of the machine are determined by standing behind the unit, looking in the direction of travel.

The easiest and least time-consuming removal, disassembly, and reassembly procedures are detailed in the manual. Modifying these procedures is not recommended.

New Holland skid steers are designed with emphasis on safety for operator protection. However, careless and negligent operation can still result in serious injury to persons or damage to property. Be sure to read and follow all safety instructions in this manual.

Your New Holland dealer is interested in your obtaining the most from your investment and will be glad to answer any questions you may have about your skid steer. When major service is required, your dealer's staff of trained service technicians is ready to serve you.

When in need of parts, always order genuine New Holland service parts from your New Holland dealer. Be prepared to give your dealer the model and serial number of the engine and skid steer (the location of these numbers is described later in this section). Record the serial numbers here.

Skid Steer Model _____

Skid Steer Serial Number _____

Engine Model _____

Engine Serial Number _____

_____  **CAUTION**  _____

This symbol is used throughout this book whenever your own personal safety is involved. Take time to be careful!

ABOUT IMPROVEMENTS

New Holland is continually striving to improve its products. We must, therefore, reserve the right to make improvements or changes when it becomes practical and possible to do so, without incurring any obligation to make changes or additions to the equipment sold previously.

ALL SPECIFICATIONS ARE SUBJECT TO CHANGE WITHOUT NOTICE.

COMPANY POLICY

Company policy, which is one of continuous improvement, reserves the right to make changes in design and specifications at any time without notice and without obligation to modify units previously built.

All data given in this book is subject to production variations. Dimensions and weights are approximate only and the illustrations do not necessarily show skid steers in standard condition.

PARTS AND ACCESSORIES

Genuine NEW HOLLAND parts and accessories have been specifically designed for HEW HOLLAND MACHINES.

We would like to point out that "NON-GENUINE" parts and accessories have not been examined and released by NEW HOLLAND. The installation and or use of such products could have negative effects upon the design characteristics of your machine and thereby affect its safety. NEW HOLLAND is not liable for any damage caused by the use of "NON-GENUINE" NEW HOLLAND parts and accessories.

MODEL CODES

The range of Skid Steers described in this manual is identified in the text by the engine horsepower Pferdestärke. (PS). The skid steers listed below may not be available in all countries or markets.

ENGINE	PS	MODEL
N844	40	LS160
N844T	50	LS170

PRECAUTIONARY STATEMENTS

PERSONAL SAFETY

Throughout this manual and on machine decals, you will find precautionary statements (“**CAUTION**”, “**WARNING**”, and “**DANGER**”) followed by specific instructions. These precautions are intended for the personal safety of you and those working with you. Please take the time to read them.

CAUTION

The word “**CAUTION**” is used where a safe behavioral practice according to operating and maintenance instructions and common safety practices will protect the operator and others from accident involvement.

WARNING

The word “**WARNING**” denotes a potential or hidden hazard which has a potential for serious injury. It is used to warn operators and others to exercise every appropriate means to avoid a surprise involvement with machinery.

DANGER

The word “**DANGER**” denotes a forbidden practice in connection with a serious hazard.

Failure to follow the “**CAUTION**”, “**WARNING**”, and “**DANGER**” instructions may result in serious bodily injury or death.

MACHINE SAFETY

Additional precautionary statement (“**IMPORTANT**”) is followed by specific instructions. This statement is intended for machine safety.

***IMPORTANT:** The word “IMPORTANT” is used to inform the reader of something he needs to know to prevent minor machine damage if a certain procedure is not followed.*

SAFETY PRECAUTIONS**CAUTION**

Unsafe operating practices and improper use of the skid steer and its attachments on the part of the operator can result in injuries. Observe the following safety precautions at all times:

1. For servicing, the skid steer should be on level terrain, engine stopped with the wheels blocked or the entire skid steer solidly supported with the wheels off the ground before servicing any component of the drivetrain.
2. For servicing under the operator's seat, raise the seat and pan assembly up to the raised latched position and securely latch.
3. Do not operate the skid steer unless the seat is latched in the operate position.
4. Do not service the skid steer with a raised boom unless the boom is resting on the boom lock pins.
5. Do not service the skid steer with the engine running unless the skid steer is properly and securely supported with all four wheels off the ground.
6. Use caution when servicing the unit around moving parts.
7. Do not tilt the boom and cab without proper instruction.
8. Do not tilt the boom and cab without using the proper cab tilting tool.
9. Reinstall all shields removed for service.
10. Never loosen any hydraulic connections before relieving the pressure in the hydraulic system.
11. Wear eye protection such as goggles, etc.
12. Wear ear protection such as ear plugs, etc. When you feel the noise level is uncomfortable.
13. If any servicing or adjustments require the battery to be disconnected, disconnect the (-) negative ground cable.
14. When servicing electrical components, disconnect the (-) negative ground cable.
15. If the electronic instrument cluster (eic) requires removal from the dash area or the skid steer, disconnect the (-) negative ground battery cable. This will shut off power to the eic and prevent damage to the eic board or blowing the 5-amp fuses if the board is accidentally grounded.
16. If welding is required on the skid steer, disconnect the (-) negative ground cable. failure to disconnect the battery may result in damage to the EIC (Electronic Instrument Cluster) monitoring system and other electrical components.
17. If welding is required on an attachment, remove the attachment from the skid steer.
18. Give complete and undivided attention to the job at hand so that complete control of the skid steer is maintained at all times.
19. Drive slowly over rough ground and on slopes; keep alert for holes, ditches and other irregularities that may cause the skid steer to overturn.
20. Avoid steep hillside operation which could cause the skid steer to overturn.
21. Never transport a loaded bucket at full height. Operate the skid steer with the load as low as possible until it becomes necessary to raise the boom to discharge the load into a truck, container, etc.
22. Reduce speed when turning so there is no danger of the skid steer overturning.
23. Never drive up or back up a hill or incline with a raised boom or the skid steer could overturn.
24. Always look behind you before backing the skid steer.
25. Maintain proper transmission oil level to prevent loss of hydrostatic braking.
26. Do not allow passengers to ride on the skid steer at any time.
27. Do not allow children to operate the skid steer or ride on the skid steer at any time.
28. Do not allow anyone to operate the skid steer without proper instruction. OSHA requires that all operators be instructed on the proper operation of the machine before they operate the unit.
29. Do not operate the skid steer in any position other than while in the operator's seat with the seat belt securely fastened.

30. Before starting the engine, be sure that all operating controls are in neutral and the parking brake is engaged.
31. Never operate the skid steer engine in a closed building without adequate ventilation.
32. Refuel the skid steer outdoors with the engine shut off. Replace the fuel cap securely. Use an approved fuel container. Do not smoke when handling fuel. Avoid spilling fuel.
33. After operating the engine, never touch the muffler, exhaust pipe, engine or radiator until they have had time to cool.
34. Dress appropriately - wear relatively tight-fitting clothing when operating the skid steer. Loose or torn clothing can catch in moving parts or controls.
35. Before servicing the skid steer or any of its attached equipment, be sure that the attachments are lowered to the ground or that the boom arms are supported by the boom lock pins.
36. Do not work under overhangs, electric wires, or where there is danger of a slide.
37. Wear an approved safety hat when operating the machine and while in any work area.
38. When driving the skid steer on a road or highway, use warning lights or warning devices as may be required by local or state government regulations. Headlights, warning lights and smv signs are available through your new holland dealer.
39. Keep the skid steer clean. Do not allow trash, debris or other articles to accumulate in the cab, floor or foot control pedal area that may hinder safe machine operation.
40. Never operate the skid steer with any of the shielding removed.
41. Never operate the skid steer without windows and/or screens in place.
42. Never extend any part of the body outside of the operator's area.

43. Always properly tie down the skid steer to a truck or trailer before transport.
44. Make sure all bystanders are at a safe distance away from the skid steer before starting the engine.
45. Do not allow anyone near the skid steer while the engine is running and the skid steer is operational.
46. When using the skid steer to crane objects, do not allow any person to ride on objects being craned.
47. Do not use the skid steer as a work platform for supporting materials.
48. Do not lift personnel or allow personnel to work while standing in the bucket or on other attachments. This is not a man-lift.

OSHA requirements now make it the employer's responsibility to fully instruct each operator in the proper and safe operation of all operative equipment. Both employer and employee should thoroughly familiarize themselves with the following sections.

—————  CAUTION  —————

Some pictures in this manual show safety shields removed or open to show parts being serviced or for clarity. All shields should be closed or replaced prior to operating the machine.

—————  DANGER  —————

Fasten seat belt before starting engine!
This skid steer is a very stable unit but it can be upset if stopped suddenly when the bucket is raised and loaded.
Therefore, do not start the engine before securely fastening the seat belt, and carry the load low.

GENERAL SAFETY INFORMATION

HANDLE FLUIDS SAFELY

When you work around fuel or other flammable material, do not smoke, work near heaters or other fire hazards.

Do not store flammable material in open containers.

Store flammable fluids away from fire hazards.

Do not incinerate or puncture pressurized containers.

Make sure machine is clean of trash, grease, oil, and debris.

Do not store oily rags; they can ignite and burn spontaneously.

Keep a first aid kit and fire extinguisher handy.

Keep emergency numbers for doctors, ambulance service, hospital, and fire department near your telephone.

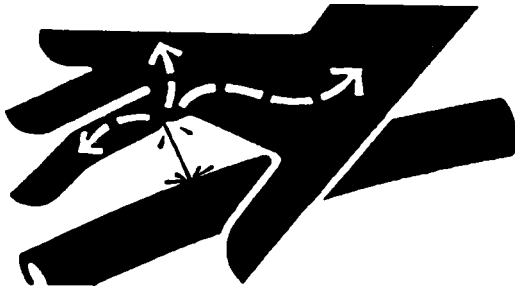

USE CARE AROUND HIGH-PRESSURE FLUID LINES

Escaping fluid under pressure can penetrate the skin causing serious injury.

Avoid the hazard by relieving pressure before disconnecting hydraulic or other lines.

Tighten all line connections before applying pressure.

Check for leaks with a piece of cardboard.

Protect hands and body from high-pressure fluids.

If an accident occurs, see a doctor immediately. Any fluid injected into the skin must be surgically removed within a few hours or gangrene may result. Doctors unfamiliar with this type of injury should reference a knowledgeable medical source.

AVOID HEATING NEAR PRESSURIZED FLUID LINES

Flammable spray can be generated by heating near pressurized fluid lines, resulting in severe burns to yourself and bystanders.

Do not heat by welding, soldering, or using a torch near pressurized fluid lines.

Pressurized lines can be accidentally cut or damaged when heat goes beyond the immediate flame area.

USE CARE IN HANDLING AND SERVICING BATTERIES

Prevent Battery Explosions

Keep sparks, lighted matches, and open flame away from the top of the battery. Battery gas can explode.

Never check battery charge by placing a metal object across the posts. Use a voltmeter or hydrometer.

Do not charge a frozen battery; it may explode. Warm the battery to 60° F (16° C).



WARNING

If any servicing or adjustments require the battery to be disconnected, or welding is required on the skid steer, disconnect the (-) negative ground cable. Failure to disconnect the battery may result in damage to the eic (electronic instrument cluster) monitoring system and other electrical components.



WARNING

If welding on an attachment is required, first remove the attachment from the skid steer boom attaching plate.



Engine starting with a booster battery requires extreme care as batteries produce explosive gases. The slightest spark can cause an explosion.

Follow these safety tips:

- 1. Always shield your eyes when charging or working near a battery. Always provide good ventilation.**
- 2. Cover the battery with a piece of carpet or other heavy material. Do not remove the battery vent caps.**
- 3. Connect one cable to the (+) positive terminal of the weak battery. Connect the other end of the cable to the (+) positive terminal of the stronger battery.**
- 4. Connect the second cable to the (-) negative terminal of the stronger battery.**
- 5. Connect the remaining (-) negative cable end to the engine block or starter ground terminal.**
- 6. Reverse this procedure when disconnecting the booster.**

USE SAFE SERVICE PROCEDURES

Wear Protective Clothing

Do not wear loose clothing.

Wear close-fitting clothing.

Wear safety glasses or face shield as required.

Wear other safety equipment appropriate to the job.

Wear earplugs or earmuffs as required.

SERVICE MACHINES SAFELY

Use caution when working around moving parts.

If servicing requires the boom to be in the raised position, support the boom on the boom locks and remove any attachment from the boom mounting

plate. If servicing requires the complete skid steer to be in the supported position, support all four wheels off the ground using adequate jack stands or blocks.

If servicing requires the engine to be operated, raise the machine and properly support the unit with adequate jack stands or blocking with all four wheels off the ground.



Before servicing the skid steer or any of its attached equipment, be sure that the attachments are lowered to the ground or the boom arms are supported by the boom lock pins.

USE PROPER TOOLS

Use tools appropriate for the job.

If tilting of the cab is required, use the proper tools and follow the procedure for tilting the cab in Section 1 of this manual.

REVIEW SAFETY EQUIPMENT, SIGNS AND SHIELDS

Replace missing or damaged safety decals.

Reinstall all shielding removed for servicing.

Replace any damaged or missing shielding.

CONTROLS

Operate unit and check machine functions for proper operation.

Check seat belt for proper operation, wear, and damage - Replace as needed.

Check operator restraint system - EIC for proper operation.

Check boom and bucket spool locks for proper operation.

Check mechanical boom locks for proper operation.

Check parking brake for proper operation and adjustment.

MACHINE MODEL AND SERIAL NUMBER LOCATION

The skid steer model and serial number tag is located on the right front interior of the operator's cab at 1.

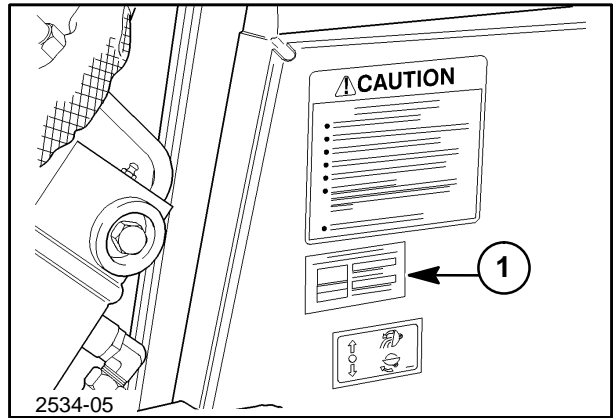

1

ENGINE MODEL AND SERIAL NUMBER LOCATION

The engine model and serial number is located on the left side of the block at 1.

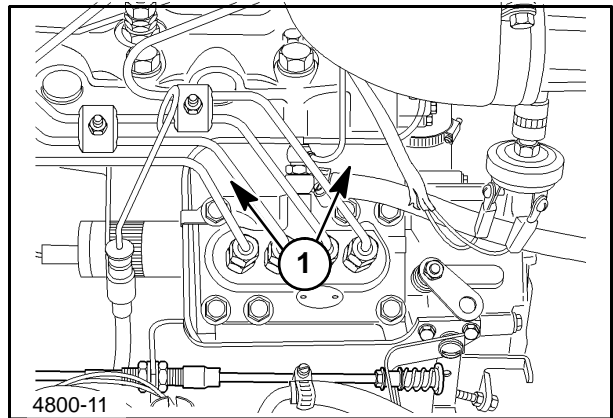

2

For the tightening torques for reassembly, use the following hardware torque chart unless the torque is specified in the instructions.

MINIMUM HARDWARE TIGHTENING TORQUES

IN FOOT POUNDS (NEWTON-METERS) FOR NORMAL ASSEMBLY APPLICATIONS

INCH HARDWARE AND LOCKNUTS

NOMINAL SIZE	SAE GRADE 2		SAE GRADE 5		SAE GRADE 8		LOCKNUTS		NOMINAL SIZE
	UNPLATED or PLATED SILVER	PLATED W/ZnCr GOLD	UNPLATED or PLATED SILVER	PLATED W/ZnCr GOLD	UNPLATED or PLATED SILVER	PLATED W/ZnCr GOLD	GR.B w/GR5 BOLT	GR.C w/GR8 BOLT	
1/4	55* (6.2)	72* (8.1)	86* (9.7)	112* (13)	121* (14)	157* (18)	61* (6.9)	86* (9.8)	1/4
5/16	115* (13)	149* (17)	178* (20)	229* (26)	250* (28)	324* (37)	125* (14)	176* (20)	5/16
3/8	17 (23)	22 (30)	26 (35)	34 (46)	37 (50)	48 (65)	19 (26)	26 (35)	3/8
7/16	27 (37)	35 (47)	42 (57)	54 (73)	59 (80)	77 (104)	30 (41)	42 (57)	7/16
1/2	42 (57)	54 (73)	64 (87)	83 (113)	91 (123)	117 (159)	45 (61)	64 (88)	1/2
9/16	60 (81)	77 (104)	92 (125)	120 (163)	130 (176)	169 (229)	65 (88)	92 (125)	9/16
5/8	83 (112)	107 (145)	128 (174)	165 (224)	180 (244)	233 (316)	90 (122)	127 (172)	5/8
3/4	146 (198)	189 (256)	226 (306)	293 (397)	319 (432)	413 (560)	160 (217)	226 (306)	3/4
7/8	142 (193)	183 (248)	365 (495)	473 (641)	515 (698)	667 (904)	258 (350)	364 (494)	7/8
1	213 (289)	275 (373)	547 (742)	708 (960)	773 (1048)	1000 (1356)	386 (523)	545 (739)	1

NOTE: Torque values shown with * are inch pounds.

IDENTIFICATION CAP SCREWS AND CARRIAGE BOLTS



LOCKNUTS

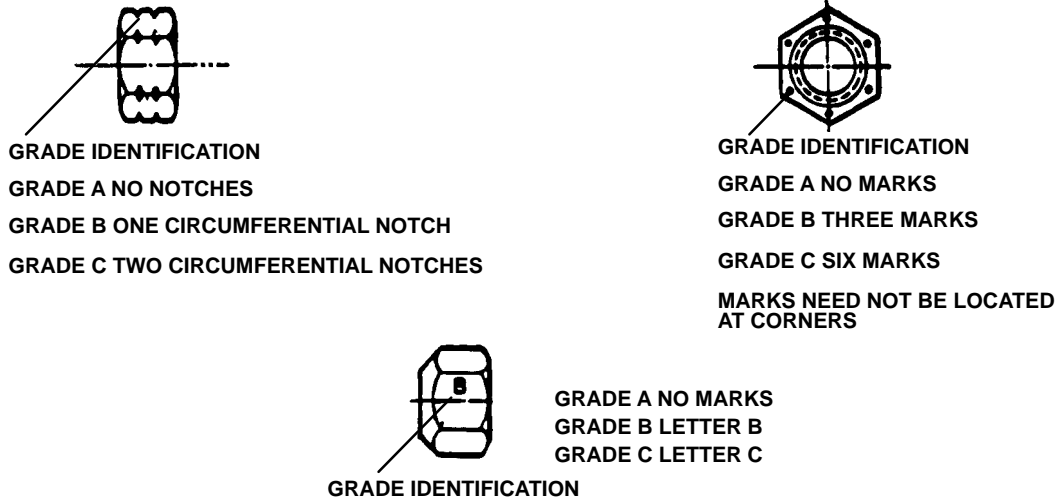

MINIMUM HARDWARE TIGHTENING TORQUES

IN FOOT POUNDS (NEWTON-METERS) FOR NORMAL ASSEMBLY APPLICATIONS

METRIC HARDWARE AND LOCKNUTS

NOMINAL SIZE	CLASS 5.8		CLASS 8.8		CLASS 10.9		LOCKNUT CL.8 W/CL8.8 BOLT
	UNPLATED	PLATED W/ZnCr	UNPLATED	PLATED W/ZnCr	UNPLATED	PLATED W/ZnCr	
M4	15* (1.7)	19* (2.2)	23* (2.6)	30* (3.4)	33* (3.7)	42* (4.8)	16* (1.8)
M6	51* (5.8)	67* (7.6)	79* (8.9)	102* (12)	115* (13)	150* (17)	56* (6.3)
M8	124* (14)	159* (18)	195* (22)	248* (28)	274* (31)	354* (40)	133* (15)
M10	21 (28)	27 (36)	32 (43)	41 (56)	45 (61)	58 (79)	22 (30)
M12	36 (49)	46 (63)	55 (75)	72 (97)	79 (107)	102 (138)	39 (53)
M16	89 (121)	117 (158)	137 (186)	177 (240)	196 (266)	254 (344)	97 (131)
M20	175 (237)	226 (307)	277 (375)	358 (485)	383 (519)	495 (671)	195 (265)
M24	303 (411)	392 (531)	478 (648)	619 (839)	662 (897)	855 (1160)	338 (458)

NOTE: Torque values shown with * are inch pounds.

IDENTIFICATION HEX CAP SCREW AND CARRIAGE BOLTS CLASSES 5.6 AND UP

MANUFACTURER'S IDENTIFICATION

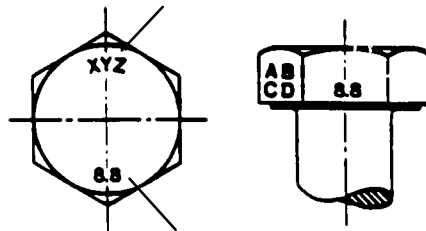

PROPERTY CLASS

HEX NUTS AND LOCKNUTS CLASSES 05 AND UP

MANUFACTURER'S IDENTIFICATION

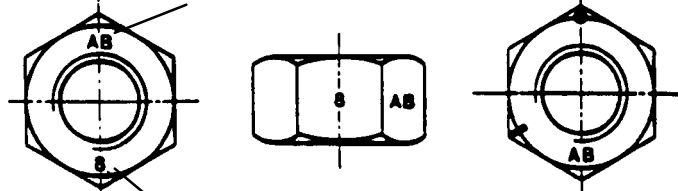

PROPERTY CLASS

CLOCK MARKING

INSTALLATION OF ADJUSTABLE FITTINGS IN STRAIGHT THREAD O RING BOSSES

1. Lubricate the O ring by coating it with a light oil or petroleum. Install the O ring in the groove adjacent to the metal backup washer which is assembled at the extreme end of the groove, 4.
2. Install the fitting into the SAE straight thread boss until the metal backup washer contacts the face of the boss, 5.

NOTE: Do not over tighten and distort the metal backup washer.

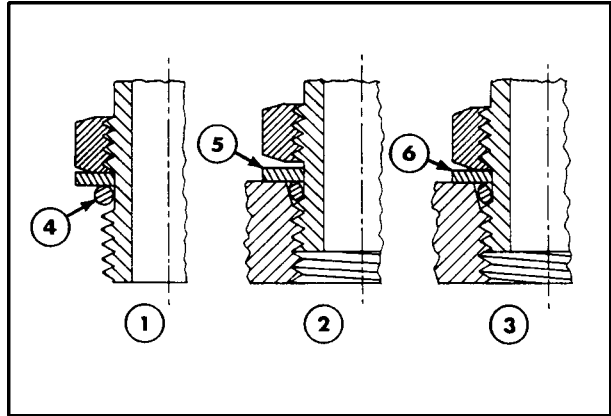

3. Position the fitting by turning out (counterclockwise) up to a maximum of one turn. Holding the pad of the fitting with a wrench, tighten the locknut and washer against the face of the boss, 6.

3

STANDARD TORQUE DATA FOR HYDRAULIC TUBES AND FITTINGS

SIZE	TUBING OD		THREAD SIZE	TUBE NUTS FOR 37° FLARED FITTINGS				O RING BOSS PLUGS ADJUSTABLE FITTING LOCKNUTS, SWIVEL JIC - 37° SEATS			
	mm	In.		TORQUE		TORQUE		TORQUE		TORQUE	
				NEWTON METERS	FOOT POUNDS	NEWTON METERS	FOOT POUNDS	NEWTON METERS	FOOT POUNDS	NEWTON METERS	FOOT POUNDS
				Min.	Max.	Min.	Max.	Min.	Max.	Min.	Max.
4	6.4	1/4	7/16-20	12	16	9	12	8	14	6	10
5	7.9	5/16	1/2-20	16	20	12	15	14	20	10	15
6	9.5	3/8	9/16-18	29	33	21	24	20	27	15	20
8	12.7	1/2	3/4-18	47	54	35	40	34	41	25	30
10	15.9	5/8	7/8-14	72	79	53	53	47	54	35	40
12	19.1	3/4	1-1/16-12	104	111	77	82	81	95	60	70
14	22.2	7/8	1-3/16-12	122	136	90	100	95	109	70	80
16	25.4	1	1-5/16-12	149	163	110	120	108	122	80	90
20	31.8	1-1/4	1-5/8-12	190	204	140	150	129	158	95	115
24	38.1	1-1/2	1-7/8-12	217	237	160	175	163	190	120	140
32	50.8	2	2-1/2-12	305	325	225	240	339	407	250	300

These torques are not recommended for tubes of 12.7 mm (1/2") OD and larger with wall thickness of 0.889 mm (0.035") or less. The torque is specified for 0.889 mm (0.035") wall tubes on each application individually.

solvent or Loctite cleaner and apply hydraulic sealant Loctite no. 569 to the 37° flare and the threads.

Install fitting and torque to specified torque, loosen fitting and retorque to specifications.

Before installing and torquing 37° flared fittings, clean the face of the flare and threads with a clean

SECTION 00 - GENERAL INFORMATION

PIPE THREAD FITTING TORQUE

Thread Size	Torque (Maximum)
1/8" – 27	13 N·m (10 ft. lbs.)
1/4" – 18	16 N·m (12 ft. lbs.)
3/8" – 14	22 N·m (16 ft. lbs.)
1/2" – 14	41 N·m (30 ft. lbs.)
3/4" – 14	54 N·m (40 ft. lbs.)

Before installing and tightening pipe fittings, clean the threads with a clean solvent or Loctite cleaner and apply sealant Loctite no. 567 for all fittings including stainless steel or no. 565 for most metal fittings. For high filtration/zero contamination systems use no. 545.

LUBRICANTS AND COOLANTS

Application	New Holland Part Number	Specification
Gearboxes	1 qt – #9613295 2.5 gal – #9613294 4 L – #9613375	SAE 80W-90
Final Drive chain case	1 qt – #9613313 2.5 gal – #9613314 1 L – #9613358 20 L – #9613360	API Service SH–CG4 10W-30
Hydraulic/Transmission	1 qt – #9613313 2.5 gal – #9613314 1 L – #9613358 20 L – #9613360	API Service SH–CG4 10W-30
All lubrication fittings	Tube – #9613310	High viscosity lithium base grease
Engine	1 qt – #9613313 2.5 gal – #9613314 1 L – #9613358 20 L – #9613360	API Service SH–CG4 10W-30 Refer to Operator's Manual for Temperature/Oil Usage Chart
Cooling System	1 gal – #FGCC2701DS	Antifreeze/Water 50/50 Mixture (Ethylene Glycol)

SEALANTS

Description	New Holland Part Number	Typical Applications	Strength	Color
Thread Lock	L22200 (222) L24231 (242) L29000 (290) L26231 (262)	Small Screws/Hardware Nuts and Bolts Wicking Type Nuts and Bolts	Low Medium Medium High	Purple Blue Green Red
Thread Sealants	L54531 (545) L56531 (565) L56747 (567)	Hydraulic/Pneumatic Pipe Sealant Pipe Sealant	Non-Fouling Controlled Strength High Temperature	
Silicones	L81724 (3.5 oz. tube) L58775 (10.2 oz. cartridge) L82180 (3.35 oz. tube) L59875 (10.2 oz. cartridge)	Ultra Blue RTV Gasket Ultra Blue RTV Gasket Ultra Blue RTV Gasket Ultra Blue RTV Gasket	Non-corrosive Non-corrosive Non-corrosive Non-corrosive	Blue Blue Black Black

PROPERLY SUPPORT A RAISED MACHINE

If servicing neutral adjustment, final drive adjustment or repairs requiring the machine to be raised, securely support the machine with adequate jack stands or blocks as shown.

Support the machine at 1 to the front of the final drive cases and to the rear at 2, making sure the supports are on the flat area of the final drive cases.

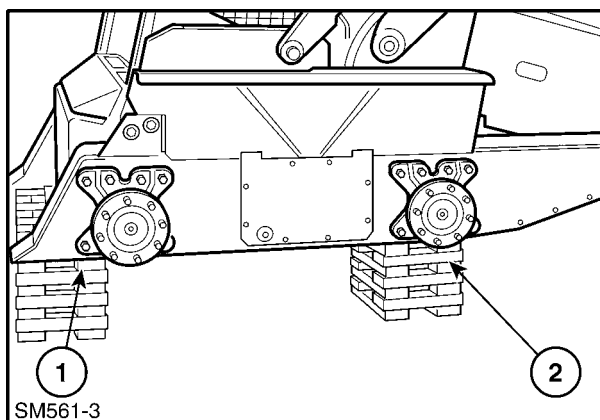

4

PROPERLY SUPPORT BOOM ON BOOM LOCK PINS

Before servicing the machine or any of its attached equipment, be sure that the attachments are lowered to the ground or the boom arms are supported by the boom lock pins, 1.

If the boom is to be raised on the boom lock pins, remove any attachment. Opening a hydraulic line could cause a mounted attachment to dump over unexpectedly.

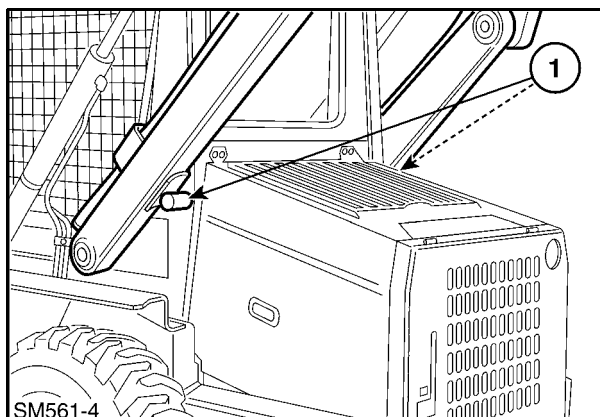

5

RAISING BOOM WITHOUT HYDRAULIC OIL FLOW

(Engine or Hydraulic System not functioning)

1. Remove any attachment from the boom mounting plate.
2. Block the rear of the skid steer under the rear of the final drive cases, 1, as shown. This will prevent the front wheels from raising during boom lifting.

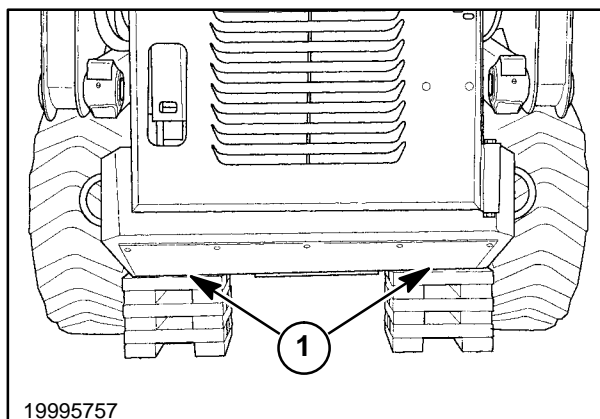

6

SECTION 00 - GENERAL INFORMATION

3. Attach a chain or strap, 1, to the main boom, 2, and lifting device, 3. Attach chain or strap securely to prevent unhooking during boom lifting.

CAUTION

Attach suitable chains or straps capable of handling the weight of the boom, 454 kg (1000 lbs). Attach chains securely to prevent them from coming loose during lifting of the boom.

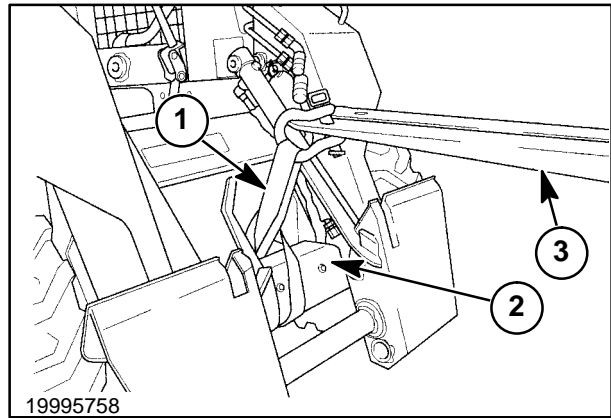

7

4. With an Operator sitting in the Operator's seat with the seat belt buckled.
5. Turn the ignition key to the "ON" position. Foot controls, press the toe of the left foot pedal, boom control, or hand controls, pivot the left hand control lever down, into the boom float position.
6. Slowly raise the boom above the boom lock pins, 1.
7. Operator sitting in seat, engage the boom lock pins, 1.
8. Lower the boom and rest on the boom lock pins, 1.
9. Return the boom control to the "NEUTRAL" position.
10. Turn the ignition key to the "OFF" position.

CAUTION

The operator must not leave the operator's seat until the boom is resting solidly on the boom lock pins. The boom could drop suddenly if lifting devices should fail.

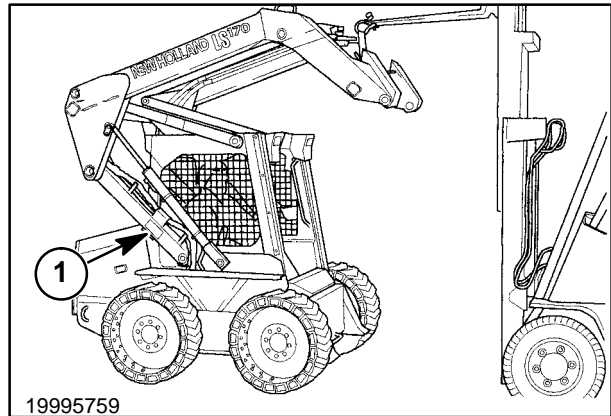

8

RAISING BOOM WITHOUT BATTERY VOLTAGE (12 VOLTS)

1. Remove any attachment from the boom mounting plate.
2. Block the rear of the skid steer under the rear of the final drive cases, 1, as shown. This will prevent the front wheels from raising during boom lifting.

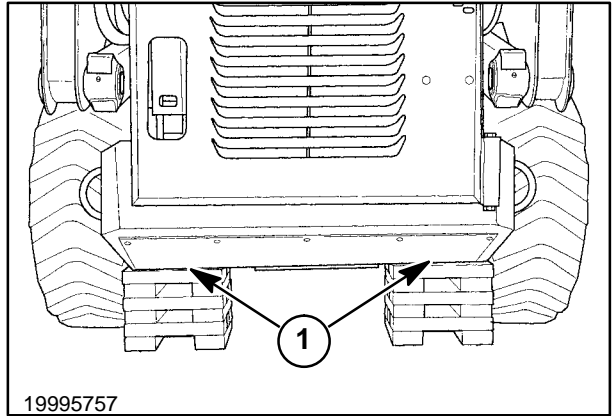

9

3. Attach a chain or strap, 1, to the main boom, 2, and lifting device, 3. Attach chain or strap securely to prevent unhooking during boom lifting.



Attach suitable chains or straps capable of handling the weight of the boom, 454 kg (1000 lbs). Attach chains securely to prevent them from coming loose during lifting of the boom.

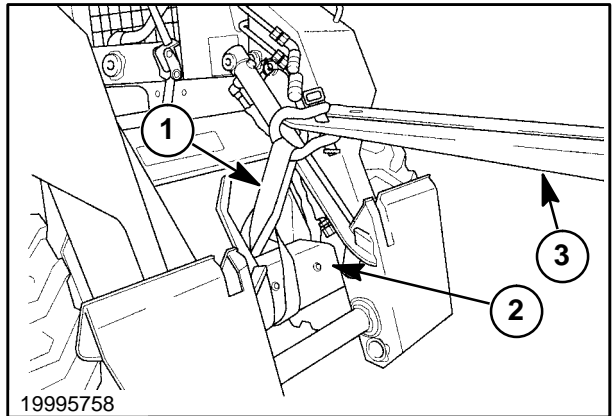

10

4. Remove the rod end (top) pivot pins, 1, from both cylinders by removing the retaining hardware, 2, from pivot pin and boom.

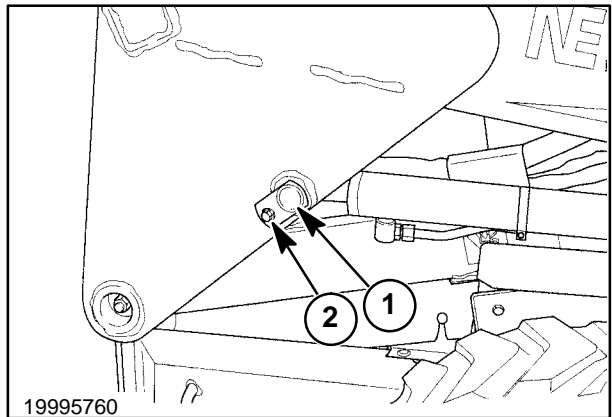

11

5. Support the cylinders on the fenders, 1, as shown.

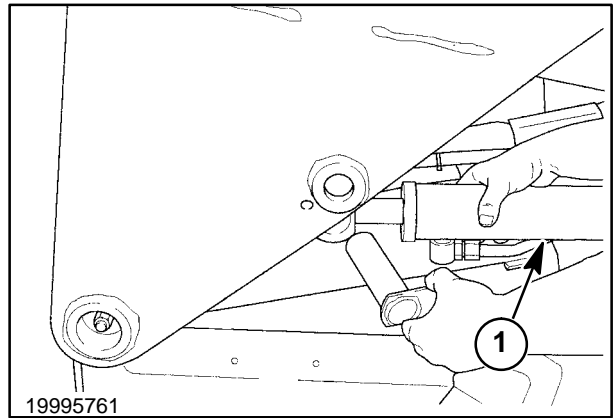

12

6. With an Operator sitting in the Operator's seat with the seat belt buckled, slowly raise the boom above the boom lock pins, 1.
7. Operator (sitting in the seat) engages the boom lock pins, 1.
8. Lower the boom and rest on the boom lock pins, 1.



The operator must not leave the operator's seat until the boom is resting solidly on the boom lock pins. The boom could drop suddenly if lifting devices should fail.

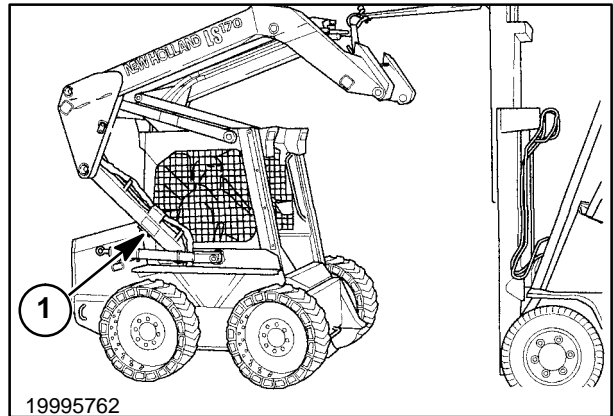

13

REATTACHING CYLINDERS AFTER REPAIR WITH BOOM RESTING ON BOOM LOCK PINS

1. Support the rod end of cylinders, 1, off the boom upper links, 2, to align with main boom cylinder pivot pin holes, 3.

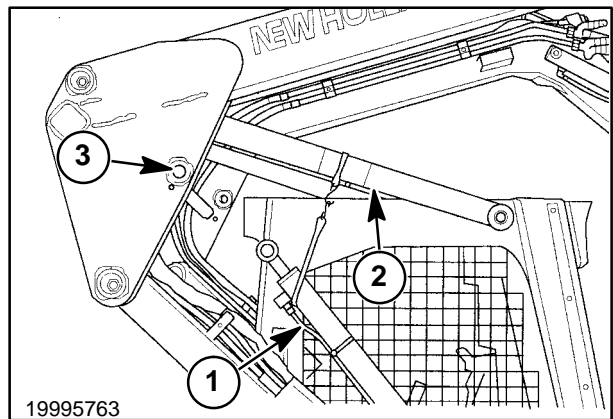

14

2. With operator sitting in the Operator's seat with seat belt buckled, start the engine and hydraulically extend cylinder rods to align cylinder with pivot pin, 1. Stop engine.
3. Turn the ignition key to the "ON" position. Move the boom control into "DETENT" (float) position with the left foot pedal (press toe down) or left hand control (push control lever down). Turn the ignition key to the "OFF" position.
4. If cylinder and boom are not properly aligned, use a pry bar to align cylinder and boom.
5. Install pivot pin, 1, and secure with retaining hardware, 2. Torque bolts to 38 N·m (28 ft. lbs.).
6. Start the engine and hydraulically extend the second cylinder rod to align cylinder with pivot pin. Stop engine.
7. If cylinder and boom are not properly aligned, sit in the operator's seat with seat buckled, turn the ignition key to the "ON" position. Move the boom control to the "DETENT (float) position and turn the ignition key to the "OFF" position.
8. Use a pry bar and align cylinder with boom and install pivot pin, 1, and retaining hardware, 2, and torque to 38 N·m (28 ft. lbs.).

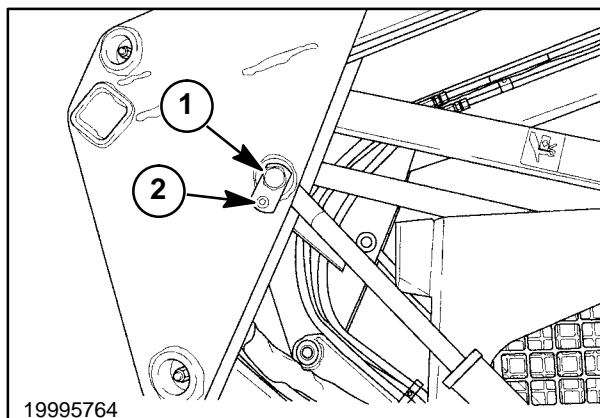

19995764

15

MAJOR UNIT OVERHAUL

For a major hydrostatic component or engine repair, the skid steer cab and boom assembly can be tilted forward for easier access to the components area. The figure shows the skid steer properly supported and the cab tilted forward.



Never attempt to tilt the skid steer cab without using the proper tool and instructions. See more detail later in this section of the manual and/or contact your new holland dealer.

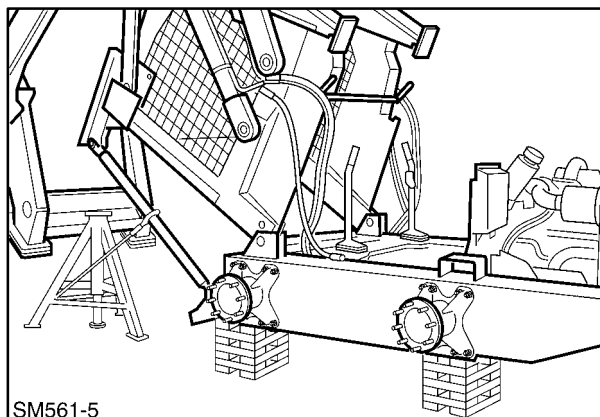

SM561-5

16

CAB AND BOOM TILT PROCEDURE

The cab and boom assembly can be tilted forward for easier access to the major skid steer hydrostatic transmission or engine components. To tilt the cab, the proper cab tilting tool must be used to ensure safety and to prevent damage to the skid steer frame, cab, and boom structure. Contact your New Holland dealer for major service or repairs of the skid steer. Using the proper cab tilting tool and following these steps, the cab and boom can be tilted forward.

1. Remove any attachment, bucket, etc. from the boom quick-attach plate.

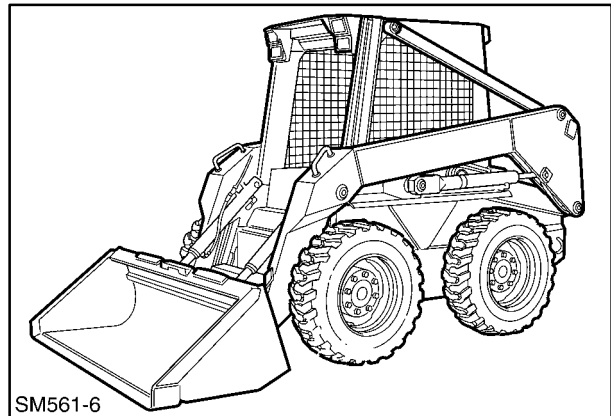

17

Cab tilting jack and support brackets:

- 1 Jack and screw assembly
- 2 Lower support
- 3 Upper support
- 4 Spacer top link

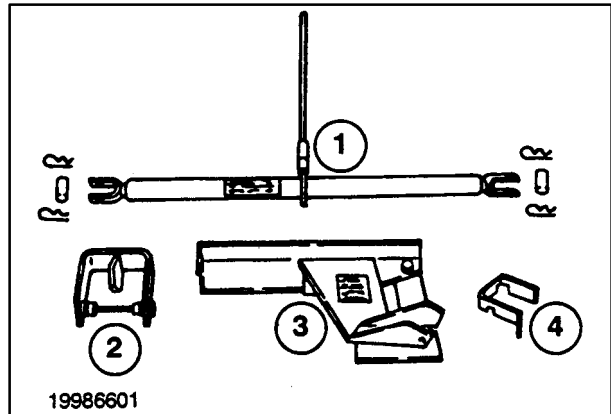

18

2. Raise the boom and lower onto boom lock pins, 1.
 - Raise boom above boom lock pins.
 - Engage boom lock pins.
 - Stop engine, ignition key off position.
 - Turn ignition key to the on position.
 - Lower boom onto boom lock pins.
 - Turn the ignition key to the "OFF" position.

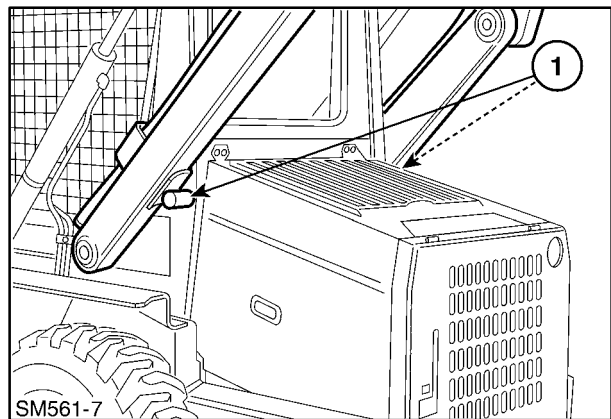

19

SECTION 00 - GENERAL INFORMATION

3. Jack up the skid steer and block it securely with all four wheels off the ground, as shown. Position the front blocks, 1, to the front of the final drive housings and the rear blocks, 2, to the rear of the flat area of the final drive housings.



Never attempt to tilt the skid steer cab over unless the skid steer is securely supported.

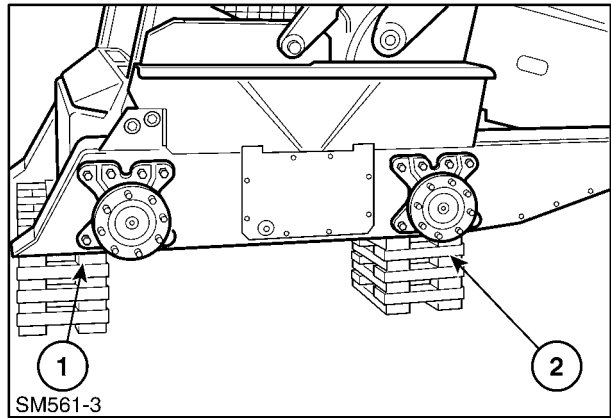

20

4. Open the rear door, 1. Raise the top engine shield, 2, and latch in the raised position.
5. Remove engine side covers, 3.

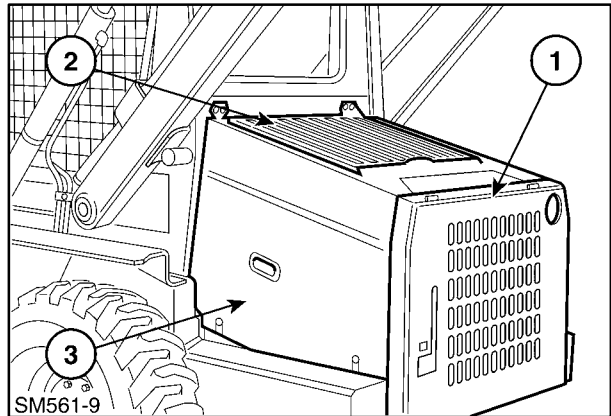

21

6. Disconnect the battery negative (-) cable, 1.

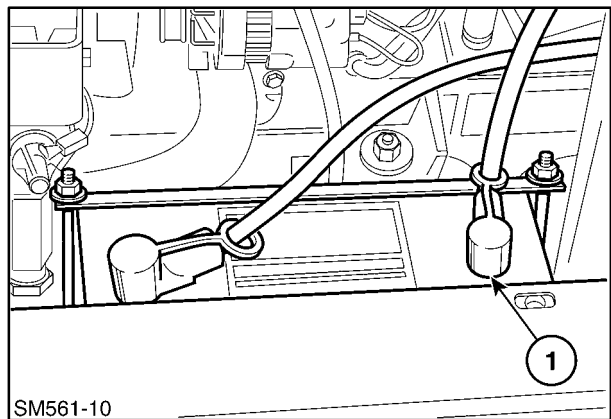

22

**Thanks very much for your reading,
Want to get more information,
Please click here, Then get the complete
manual**

JustClickHere 

NOTE:

**If there is no response to click on the link above,
please download the PDF document first, and then
click on it.**

**Have any questions please write to me:
admin@servicemanualperfect.com**